



Controls for a world in motion

PUSH-PULL CABLES CONTROL SYSTEMS



WESCON CONTROLS

WESCON'S PUSH-PULL CONTROL SYSTEMS



Push-Pull Cable Ends

Wescon Push-Pull Cable Assemblies are available in either groove or bulkhead end configurations. Also upon request Wescon offers a bulkhead/groove combination fitting in 40 and 60 series controls.

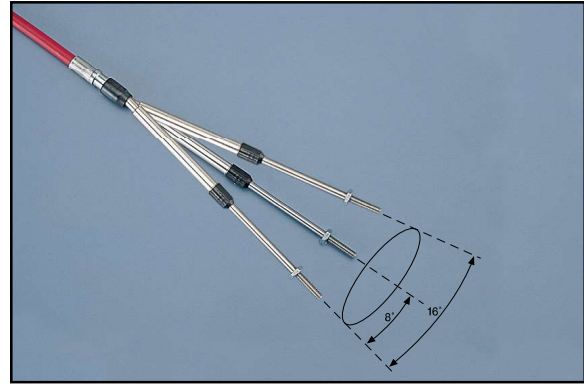

Wescon's Swivels Allow Deflection

Standard end fittings feature built-in swivels which allow an 8° deflection each side of center, or a total conical deflection of 16°, to accommodate the movement of the control arm.



Accelerator Cables

Wescon's Accelerator Cables (For pull applications only) are available in 30 and 40 series cables, and offer 2" and 3" travel options.



High Temperature Conduit

Wescon's High Temperature Blue Conduit is available in 30 and 40 series, and provides reliable operation in temperature ranges from -65° to 300° F.

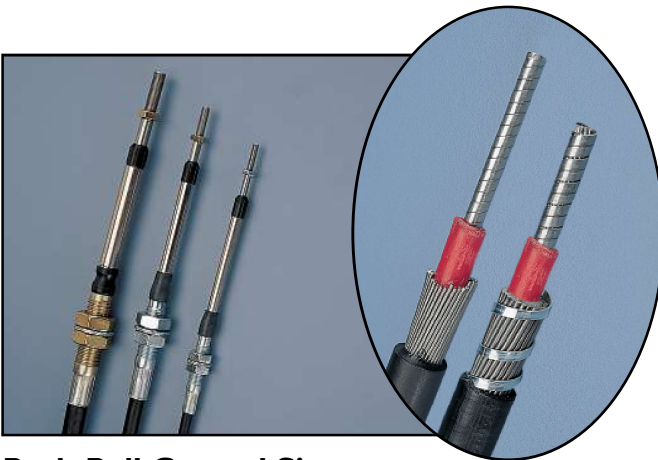

Push-Pull Control Sizes

Wescon's Push-Pull Controls are available in 30, 40, 60 and 80 series cables. Length of the cable, control resistance and operating conditions help determine cable size. See pages 4-7 for control options and configurations.



Accessories

Wescon's Accessories offer a wide variety of end terminations and mounting variations. See pages 10 and 11 for available accessories.

Conduit

Wescon's Long-Lay Conduit Construction

Wescon's long-lay conduit construction incorporates multiple strands of oil-tempered carbon spring steel wires to withstand high tension and compression with minimum deflection under load, while providing superior protection for the load carrying core. For severe routing applications, **40 Series** conduit has been developed with more lay wires of a smaller diameter for increased flexibility. As with any type of conduit, the tighter the bend radius, the shorter the life of the core. The extraordinary life of the conduit in Wescon controls is due to its tough polyethylene covers. These covers seal out environmental contaminants and dirt, while resisting abrasion and common solvents. The cover construction stands up to exposure to sunlight and temperature extremes ranging from -65° F to +225° F. Optional nylon covering is available for high temperature applications to +300° F.

Wescon's Binder-Wrapped Conduit Construction

An option to the long-lay conduit construction is the flat steel binder-wrapped conduit. This construction is desirable in applications requiring higher compression loading of the conduit.

Wescon's Maximum Efficiency Liners

Specially formulated High Density Polyethylene liners (as well as special formulations for high temperature applications) minimize friction for maximum efficiency. The inside diameter is precisely controlled, minimizing lost motion and premature wear.

End Rods, Tubes, Hardware

All standard conduit fittings are plated steel. Guide tubes are nickel-plated brass. Rods are stainless steel. In addition, all bulk-packed Wescon cables are furnished with protective vinyl caps installed over threads to prevent damage during shipment and handling. Stainless steel conduit fittings and mounting hardware are available for marine and other demanding applications.

Inner-Core

Wescon's Core Wire

Wescon's core wire choices include:

- (1) **.085 Diameter Solid polished Stainless Steel wire** for 30 series conduit only, providing higher load capabilities with somewhat lower flexibility.
- (2) **1 x 19 armor core**, consisting of Stainless Steel flat wire swaged over galvanized steel (1 x 19) stranded cable and burnished to a smooth, close tolerance finish, providing high flexibility with moderate load capabilities.
- (3) **1 x 13 armor core**, consisting of Stainless Steel flat wire swaged over galvanized steel (1 x 13) stranded cable and burnished to a smooth, close tolerance finish, providing higher load capabilities with lower flexibility. Not available for 40 series Binder wrap construction. These core designs provide a smooth, low friction finish to combine high column strength, when needed, with the flexibility required to fit a wide range of applications.
- (4) **1 x 7 nylon covered core**, (40 and 60 Series Only) consisting of 1 x 7 stranded galvanized cable covered w/nylon to provide a higher efficiency, lower lost motion, more flexible push-pull control for moderate load capabilities.

Lubrication

Special formulated lubricants are factory installed along the length of the control cable and in areas of excessive wear for years of maintenance-free, high efficiency operation.

Wescon's Optional Super Rod Seals

Wescon's special custom molded SUPER SEAL design assures a smooth cable operation. The seals, in conjunction with our fine finish 303 stainless steel rods, reduce contamination by keeping foreign materials (such as dirt and moisture) off the bearing surfaces. This mating of the SUPER SEAL with the superior rod finish results in a longer cable life without sacrificing efficiency. (Available at extra cost. Not available in 80 Series)

Input Loads

To calculate Input Loads for Wescon Push-Pull Cables, use the following formula and chart:

$$\text{Input Load (lbs)} = \text{Output Load (lbs)} \times \text{Efficiency Factor}$$

Degrees Bend	Efficiency Factor*
90°	1.2
180°	1.4
270°	1.6
360°	1.8

* Efficiency factor may vary depending on Input load, total degree of bend and number of cycles desired.

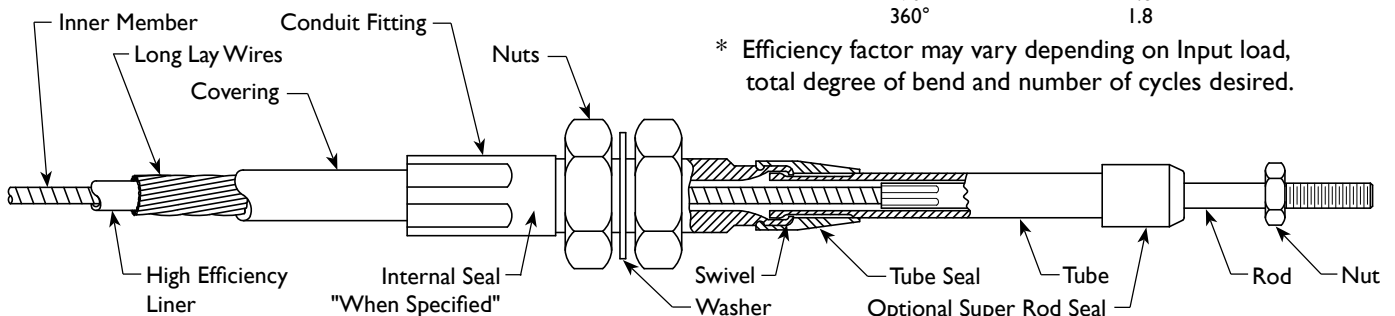

Typical applications include throttle controls, activating electrical relays or hydraulic valves and shifting hydrostatic transmissions. 6" minimum bend radius.

See page 9 for Part Number Codes.

Control Length (Inches)	"X"
Up to 60.00	± .31
60.01 to 120.00	± .50
120.01 to 240.00	± .75
Above 240.00	± 1.00

Travel	Bulkhead Type Fitting		Grooved Type Fitting		Input Load Pounds (kg)
	"A"	"B"	"C"	"D"	
1"	4.38 (111.2)	3.00 (76.2)	3.80 (96.5)	2.49 (63.2)	60 (27.2)
2"	5.87 (149.1)	4.00 (101.6)	5.31 (134.9)	3.49 (88.6)	50 (22.7)
3"	7.38 (187.4)	5.00 (127.0)	6.80 (172.7)	4.49 (114.0)	40 (18.1)
4"	8.87 (225.3)	6.00 (152.4)	8.31 (211.1)	5.49 (139.4)	30 (13.6)
5"	10.38 (263.6)	7.00 (177.8)	9.80 (248.9)	6.49 (164.8)	20 (9.1)
6"	11.77 (298.9)	8.00 (203.2)	11.31 (287.3)	7.49 (190.2)	10 (4.5)

All Dimensions are Inches (mm)

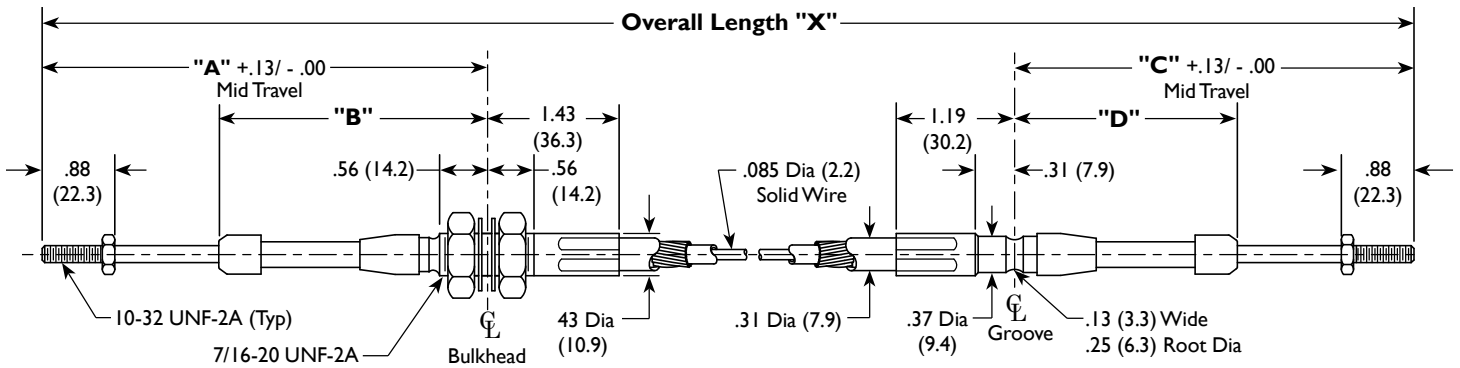

Typical applications include throttle controls, activating electrical relays or hydraulic valves and shifting hydrostatic transmissions. 6" minimum bend radius.

See page 9 for Part Number Codes.

Control Length (Inches)	"X"
Up to 60.00	± .31
60.01 to 120.00	± .50
120.01 to 240.00	± .75
Above 240.00	± 1.00

Travel	Bulkhead Type Fitting		Grooved Type Fitting		Input Load Pounds (kg)
	"A"	"B"	"C"	"D"	
1"	4.38 (111.2)	3.00 (76.2)	3.80 (96.5)	2.49 (63.2)	40 (18.1)
2"	5.87 (149.1)	4.00 (101.6)	5.31 (134.9)	3.49 (88.6)	30 (13.6)
3"	7.38 (187.4)	5.00 (127.0)	6.80 (172.7)	4.49 (114.0)	20 (9.1)
4"	8.87 (225.3)	6.00 (152.4)	8.31 (211.1)	5.49 (139.4)	10 (4.5)
5"	10.38 (263.6)	7.00 (177.8)	9.80 (248.9)	6.49 (164.8)	5 (2.3)
6"	11.77 (298.9)	8.00 (203.2)	11.31 (287.3)	7.49 (190.2)	5 (2.3)

All Dimensions are Inches (mm)

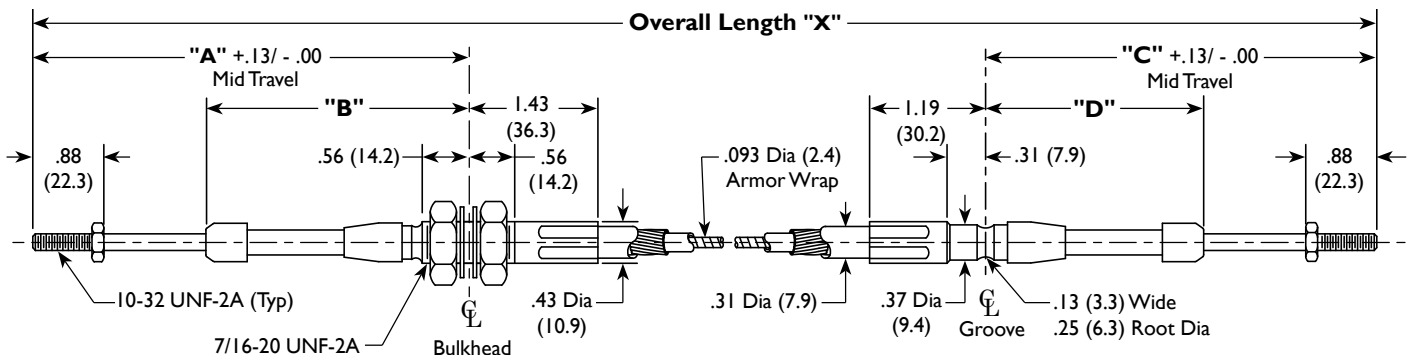



40 Series Armor Core Push-Pull Control

Typical applications include drum controls, throttle controls (cement mixers), shifting hydrostatic transmissions or activating hydraulic valves.
8" minimum bend radius.

See page 9 for Part Number Codes.

Control Length (Inches)	"X"
Up to 60.00	± .31
60.01 to 120.00	± .50
120.01 to 240.00	± .75
Above 240.00	± 1.00

Travel	Bulkhead Type Fitting		Grooved Type Fitting		Input Load Pounds (kg)
	"A"	"B"	"C"	"D"	
1"	4.62 (117.3)	3.19 (81.0)	4.00 (101.6)	2.56 (65.0)	120 (54.4)
2"	6.13 (155.7)	4.19 (106.4)	5.50 (139.7)	3.56 (90.4)	90 (40.8)
3"	7.62 (193.5)	5.19 (131.8)	7.00 (177.8)	4.56 (115.8)	75 (34.0)
4"	9.13 (231.9)	6.19 (157.2)	8.50 (215.9)	5.56 (141.2)	65 (29.5)
5"	10.62 (269.7)	7.19 (182.6)	10.00 (254.0)	6.56 (166.6)	60 (27.2)
6"	12.13 (308.1)	8.19 (208.0)	11.50 (292.1)	7.56 (192.0)	60 (27.2)

All Dimensions are Inches (mm)

NOTE:
Nuts fit over seals (typ)

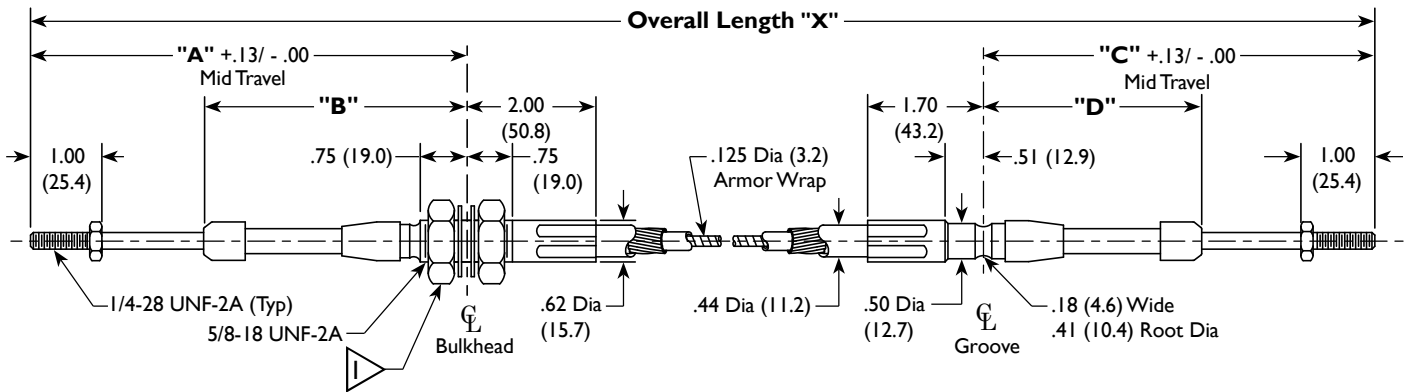

40 Series Nylon Covered Core Push-Pull Control

Typical applications include throttle/shift (rear engine bus), activating electronic transmission or activating hydraulic valves.
6" minimum bend radius.

See page 9 for Part Number Codes.

Control Length (Inches)	"X"
Up to 60.00	± .31
60.01 to 120.00	± .50
120.01 to 240.00	± .75
Above 240.00	± 1.00

Travel	Bulkhead Type Fitting		Grooved Type Fitting		Input Load Pounds (kg)
	"A"	"B"	"C"	"D"	
1"	4.62 (117.3)	3.19 (81.0)	4.00 (101.6)	2.56 (65.0)	120 (54.4)
2"	6.13 (155.7)	4.19 (106.4)	5.50 (139.7)	3.56 (90.4)	90 (40.8)
3"	7.62 (193.5)	5.19 (131.8)	7.00 (177.8)	4.56 (115.8)	75 (34.0)
4"	9.13 (231.9)	6.19 (157.2)	8.50 (215.9)	5.56 (141.2)	65 (29.5)
5"	10.62 (269.7)	7.19 (182.6)	10.00 (254.0)	6.56 (166.6)	60 (27.2)
6"	12.13 (308.1)	8.19 (208.0)	11.50 (292.1)	7.56 (192.0)	60 (27.2)

All Dimensions are Inches (mm)

NOTE:
Nuts fit over seals (typ)

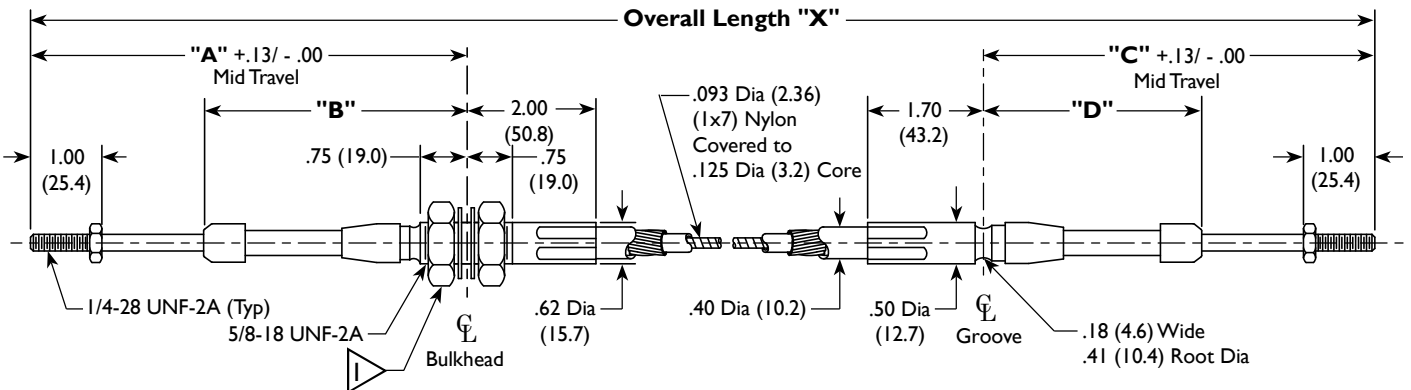

Typical applications include shifting hydrostatic or heavy duty transmissions or activating hydraulic valves.
10" minimum bend radius.

See page 9 for Part Number Codes

Control Length (Inches)	"X"
Up to 60.00	± .31
60.01 to 120.00	± .50
120.01 to 240.00	± .75
Above 240.00	± 1.00

Travel	Bulkhead Type Fitting		Grooved Type Fitting		Input Load Pounds (kg)
	"A"	"B"	"C"	"D"	
1"	5.08 (129.0)	3.38 (85.8)	4.38 (111.2)	2.68 (68.1)	220 (99.8)
2"	6.56 (166.6)	4.38 (111.2)	5.87 (149.1)	3.68 (93.5)	200 (90.7)
3"	8.06 (204.7)	5.38 (136.6)	7.38 (187.4)	4.68 (118.9)	170 (77.1)
4"	9.56 (242.8)	6.38 (162.0)	8.87 (225.3)	5.68 (144.3)	140 (63.5)
5"	11.06 (280.9)	7.38 (187.4)	10.38 (263.6)	6.68 (169.7)	110 (49.9)
6"	12.56 (319.0)	8.38 (212.8)	11.87 (301.5)	7.68 (195.1)	80 (36.3)

All Dimensions are Inches (mm)

NOTE:

Nuts fit over seals (typ)

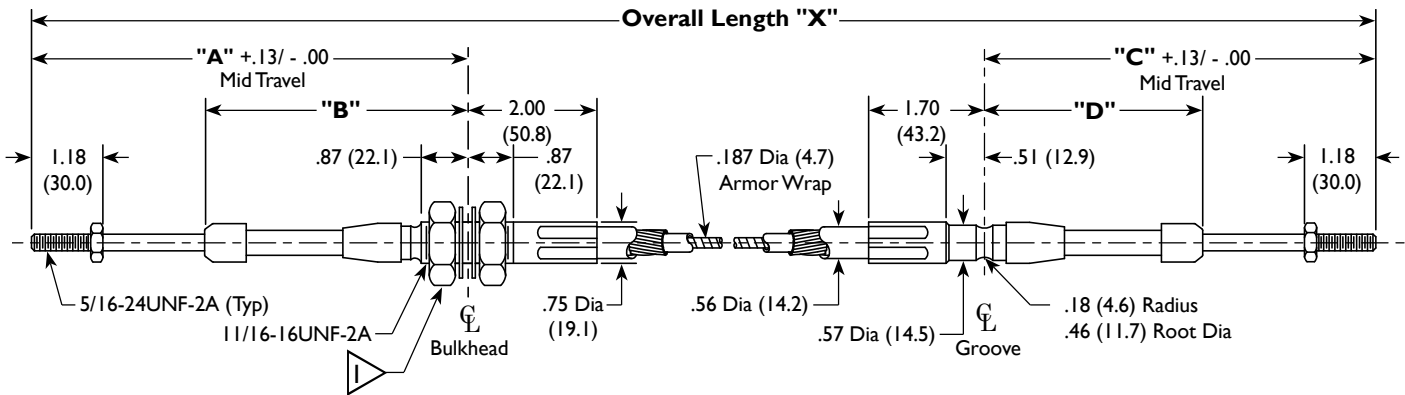

Typical applications include shifting hydrostatic or heavy duty transmissions or activating hydraulic valves.
10" minimum bend radius.

See page 9 for Part Number Codes

Control Length (Inches)	"X"
Up to 60.00	± .31
60.01 to 120.00	± .50
120.01 to 240.00	± .75
Above 240.00	± 1.00

Travel	Bulkhead Type Fitting		Grooved Type Fitting		Input Load Pounds (kg)
	"A"	"B"	"C"	"D"	
1"	5.08 (129.0)	3.38 (85.8)	4.38 (111.2)	2.68 (68.1)	220 (99.8)
2"	6.56 (166.6)	4.38 (111.2)	5.87 (149.1)	3.68 (93.5)	200 (90.7)
3"	8.06 (204.7)	5.38 (136.6)	7.38 (187.4)	4.68 (118.9)	170 (77.1)
4"	9.56 (242.8)	6.38 (162.0)	8.87 (225.3)	5.68 (144.3)	140 (63.5)
5"	11.06 (280.9)	7.38 (187.4)	10.38 (263.6)	6.68 (169.7)	110 (49.9)
6"	12.56 (319.0)	8.38 (212.8)	11.87 (301.5)	7.68 (195.1)	80 (36.3)

All Dimensions are Inches (mm)

NOTE:

Nuts fit over seals (typ)

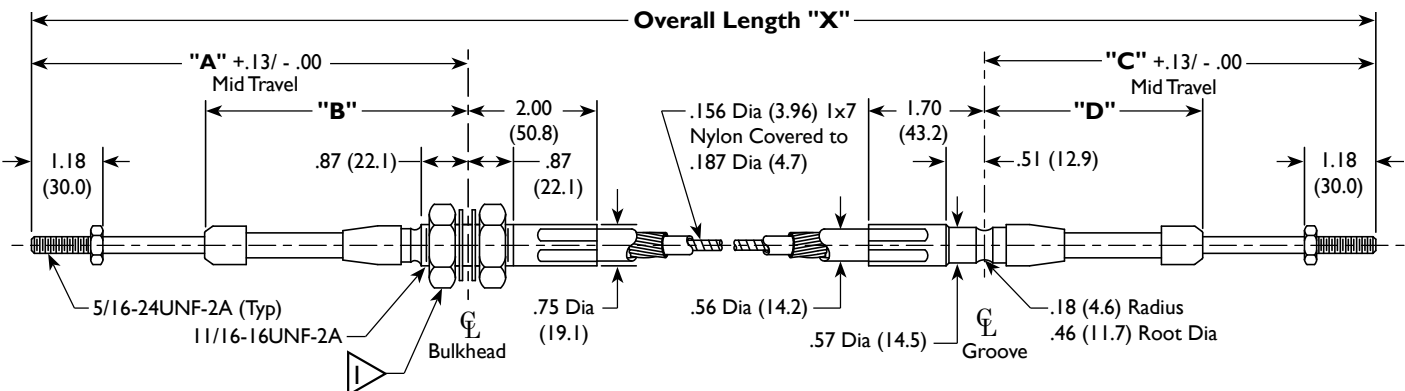



60 Series Nylon Covered Armor Core Push-Pull Control

Typical applications include shifting hydrostatic or heavy duty transmissions or activating hydraulic valves.

10" minimum bend radius.

See page 9 for Part Number Codes

Control Length (Inches)	"X"
Up to 60.00	± .31
60.01 to 120.00	± .50
120.01 to 240.00	± .75
Above 240.00	± 1.00

Travel	Bulkhead Type Fitting		Grooved Type Fitting		Input Load Pounds (kg)
	"A"	"B"	"C"	"D"	
1"	5.08 (129.0)	3.38 (85.8)	4.38 (111.2)	2.68 (68.1)	220 (99.8)
2"	6.56 (166.6)	4.38 (111.2)	5.87 (149.1)	3.68 (93.5)	200 (90.7)
3"	8.06 (204.7)	5.38 (136.6)	7.38 (187.4)	4.68 (118.9)	170 (77.1)
4"	9.56 (242.8)	6.38 (162.0)	8.87 (225.3)	5.68 (144.3)	140 (63.5)
5"	11.06 (280.9)	7.38 (187.4)	10.38 (263.6)	6.68 (169.7)	110 (49.9)
6"	12.56 (319.0)	8.38 (212.8)	11.87 (301.5)	7.68 (195.1)	80 (36.3)

All Dimensions are Inches (mm)

NOTE:

Nuts fit over seals (typ)

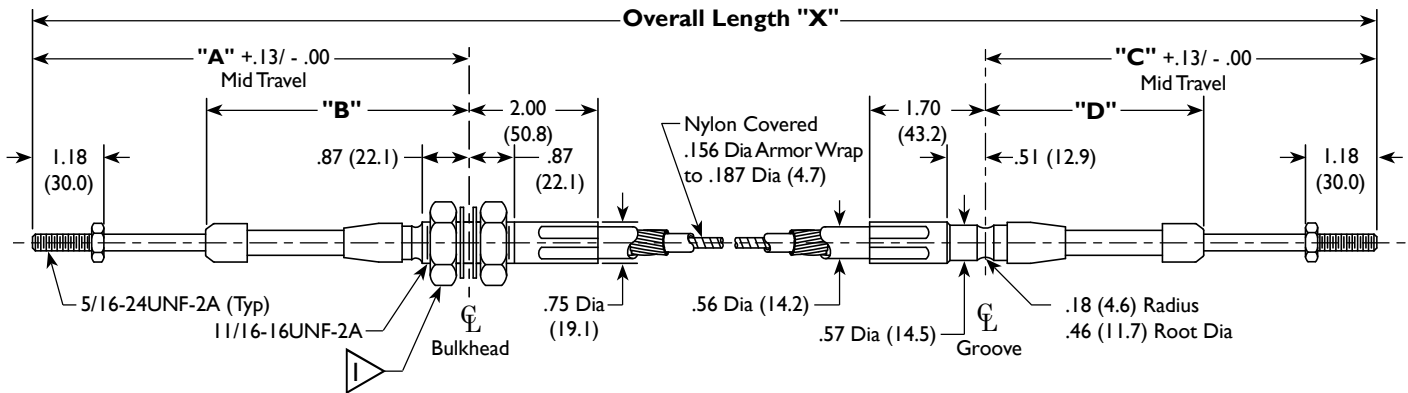

80 Series Armor Core Push-Pull Control

Typical applications include heavy duty brake or clutch controls, shifting transmissions or activating hydraulic valves.

12" minimum bend radius.

See page 9 for Part Number Codes.

Control Length (Inches)	"X"
Up to 60.00	± .31
60.01 to 120.00	± .50
120.01 to 240.00	± .75
Above 240.00	± 1.00

Travel	Bulkhead Type Fitting		Grooved Type Fitting		Input Load Pounds (kg)
	"A"	"B"	"C"	"D"	
1"	5.68 (144.3)	3.75 (95.2)	5.19 (131.8)	3.25 (82.5)	700 (315.0)
2"	7.19 (182.6)	4.75 (120.6)	6.68 (169.7)	4.25 (107.9)	700 (315.0)
3"	8.68 (220.5)	5.75 (146.0)	8.19 (208.0)	5.25 (133.3)	600 (270.0)
4"	10.19 (258.8)	6.75 (171.4)	9.68 (245.9)	6.25 (158.7)	500 (225.0)
5"	11.68 (296.7)	7.75 (196.8)	11.19 (284.2)	7.25 (184.1)	400 (180.0)
6"	13.19 (335.0)	8.75 (222.2)	12.70 (322.6)	8.25 (209.5)	300 (135.0)

All Dimensions are Inches (mm)

80 Series Controls Are Manufactured by Wescon Manufacturing Distributors Only

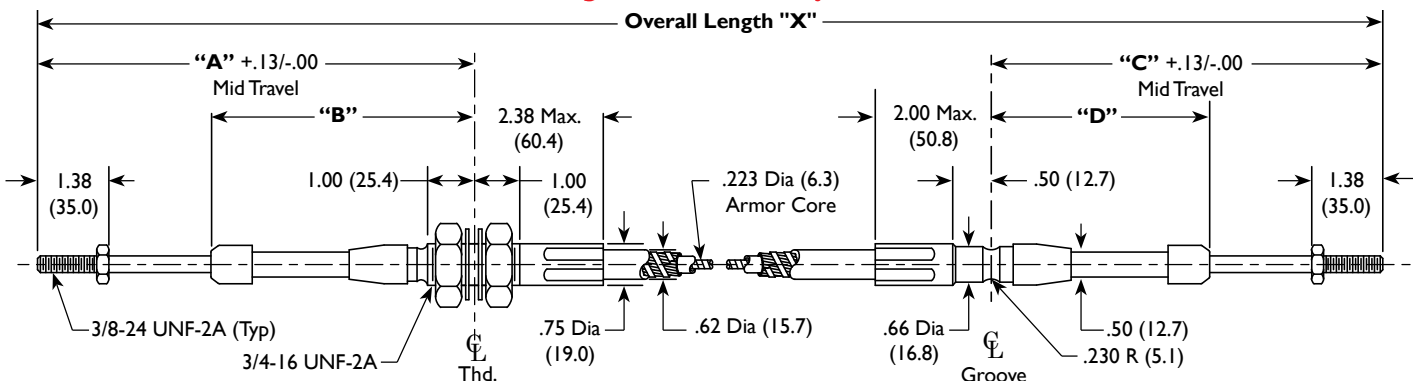

*NOTE: 80 Series Conduit is available in Binder wrap construction only.

Accelerator Cable

Available for 30 and 40 Series Cable (Pull Only)

Control Length (Inches)	"X"
Up to 60.00	± .31
60.01 to 120.00	± .50
120.01 to 240.00	± .75
Above 240.00	± 1.00

30 Series		
Travel	"A"	"B"
2"	5.87 (149.1)	5.31 (134.9)
3"	7.38 (187.4)	6.80 (172.7)

40 Series		
Travel	"A"	"B"
2"	6.13 (155.7)	5.50 (139.7)
3"	7.62 (193.5)	7.00 (177.8)

All Dimensions are Inches (mm)

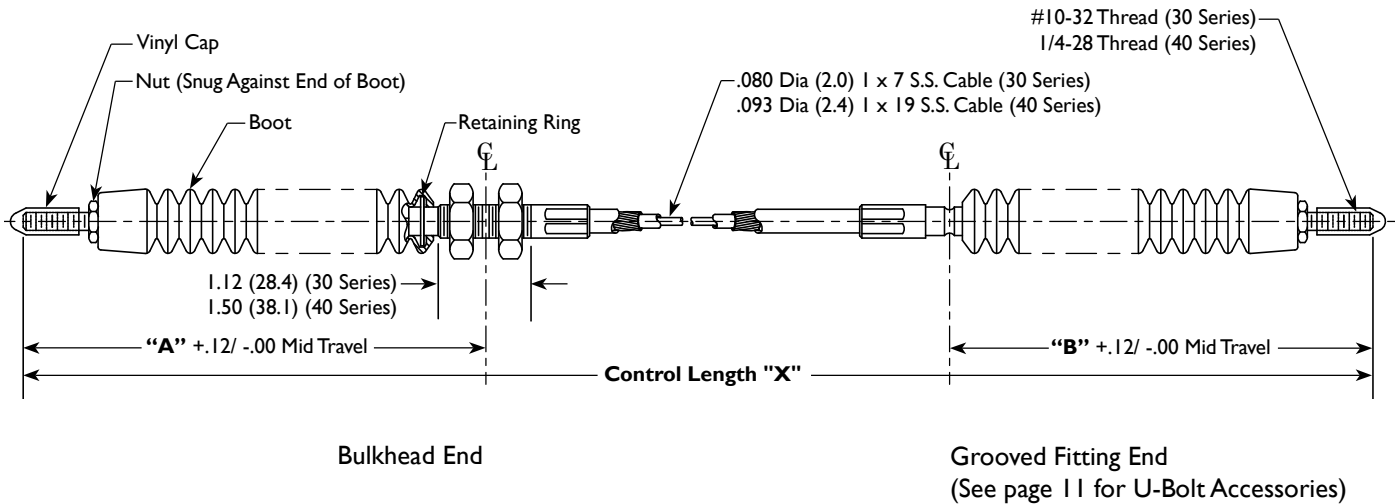

Accelerator Cable Part Number Codes

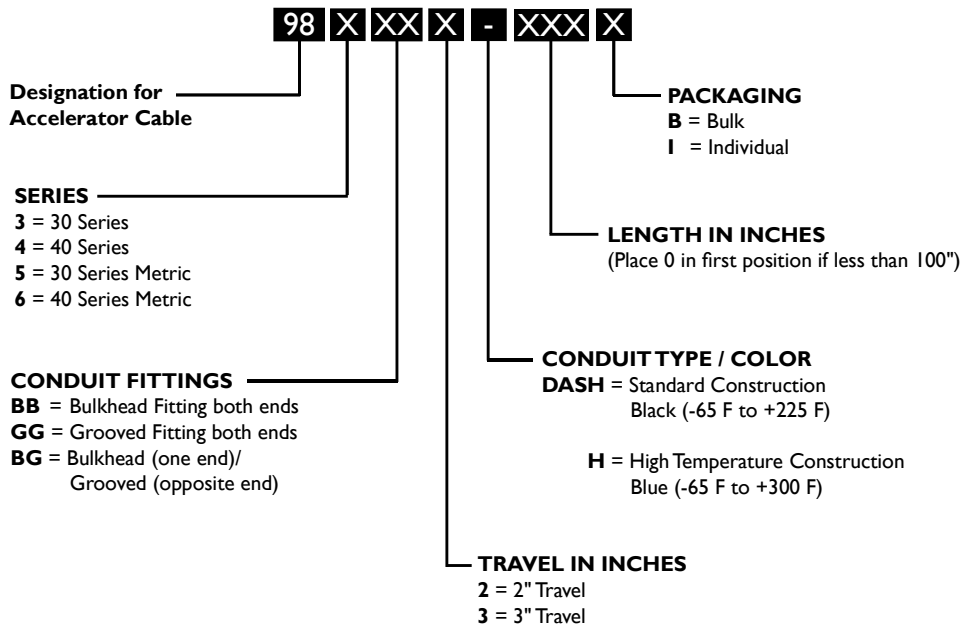

For High Load Tension Cables, See Wescon Brake Catalog

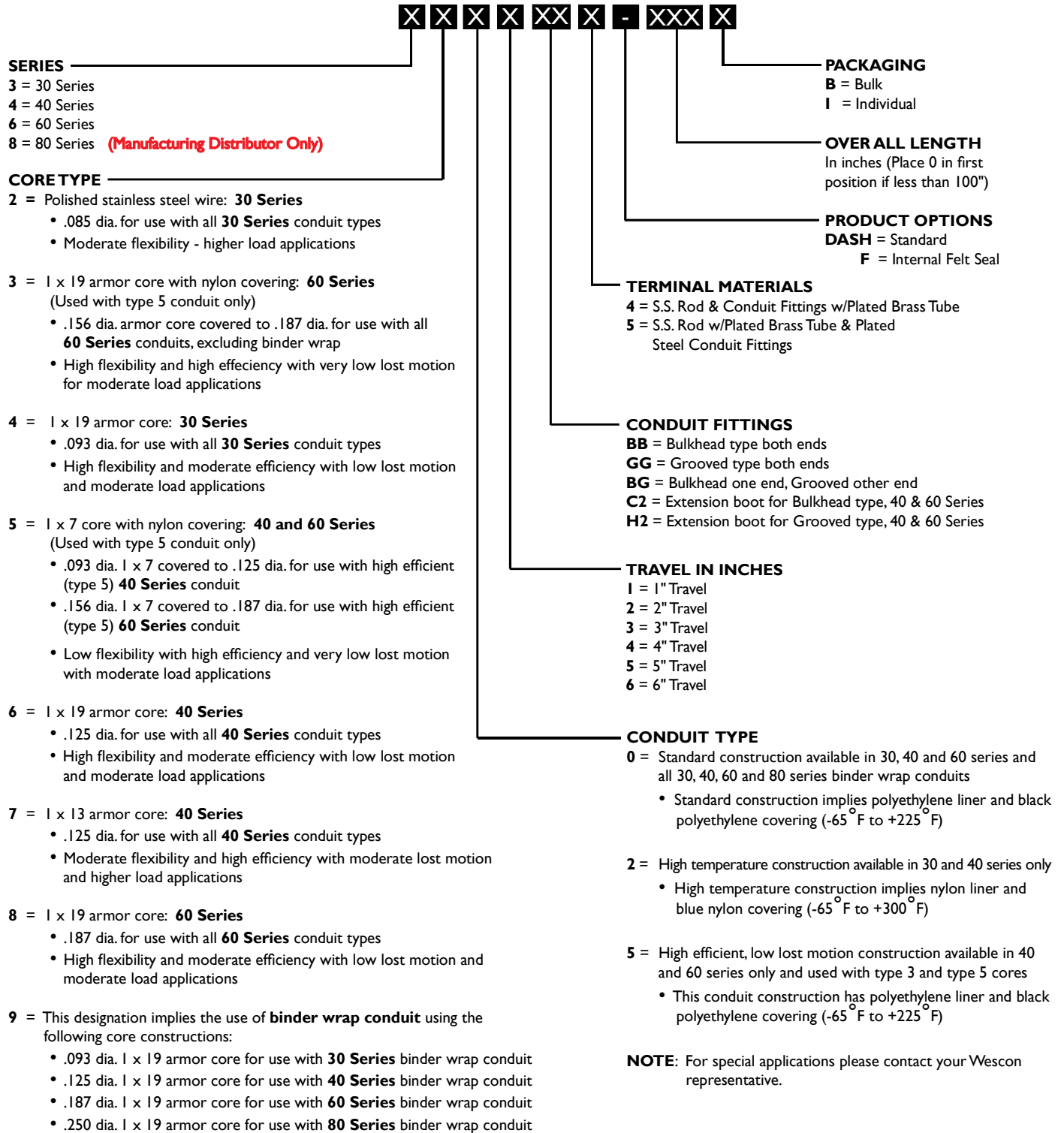

NOTE: Binder wrap conduit construction is available in standard construction only and is not available in high temperature blue.

NOTE: 80 Series is available in binder wrap conduit only.

Clevis Assembly

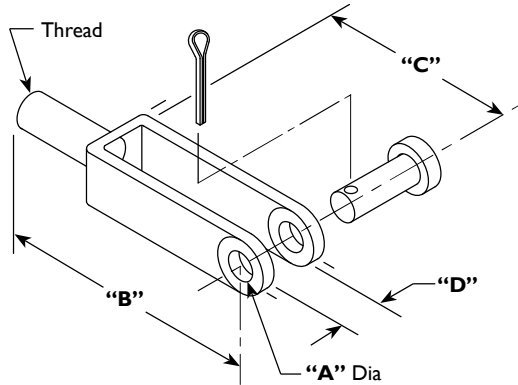

30 Series (10-32 Thread)				
Part Number	"A" Dia	"B"	"C"	"D"
06-1500-04	.187 (4.8)	1.56 (39.7)	1.00 (25.4)	.187 (4.8)
06-1500-05	.25 (6.3)	2.00 (50.8)	1.25 (31.7)	.281 (7.1)
40 Series (1/4-28 Thread)				
06-1500-01	.25 (6.3)	2.00 (50.8)	1.25 (31.7)	.281 (7.1)
06-1500-02	.31 (7.9)	2.25 (57.1)	1.44 (36.5)	.343 (8.7)
06-1500-03	.38 (9.7)	2.50 (63.5)	1.62 (41.1)	.437 (11.1)
60 Series (5/16-24 Thread)				
06-1500-06	.25 (6.3)	2.00 (50.8)	1.25 (31.7)	.281 (7.1)
06-1500-07	.31 (7.9)	2.25 (57.1)	1.44 (36.5)	.343 (8.7)
80 Series (3/8-24 Thread)				
06-1500-08	.38 (9.7)	2.50 (63.5)	1.62 (41.1)	.437 (11.1)
06-1500-09	.50 (12.7)	3.00 (76.2)	1.88 (47.8)	.562 (14.3)

All Dimensions are in inches (mm)

Pivot

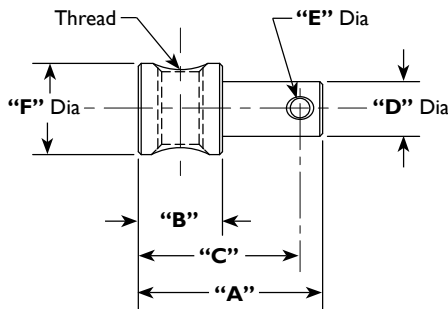

20 and 30 Series (10-32 Thread)						
Part Number	"A" Dia	"B"	"C"	"D" Dia	"E" Dia	"F" Dia
02-1601-01	.718 (18.2)	.375 (9.5)	.611 (15.5)	.187 (4.7)	.081 (2.0)	.43 (10.9)
02-1601-02	.625 (15.9)	.315 (8.0)	.496 (12.6)	.250 (6.3)	.081 (2.0)	.43 (10.9)
02-1601-03	.781 (19.8)	.310 (7.8)	.645 (16.4)	.250 (6.3)	.081 (2.0)	.43 (10.9)
02-1601-06	.750 (19.0)	.380 (9.6)	.656 (16.6)	.230 (5.8)	.093 (2.4)	.43 (10.9)
40 Series (1/4-28 Thread)						
02-1601-04	.906 (23.0)	.562 (14.3)	.743 (18.9)	.312 (7.9)	.081 (2.0)	.50 (12.7)
60 Series (5/16-24 Thread)						
02-1601-05	1.265 (32.1)	.578 (14.7)	1.109 (28.1)	.375 (9.5)	.136 (3.4)	.63 (16.0)

All Dimensions are in inches (mm)

Ball Joint

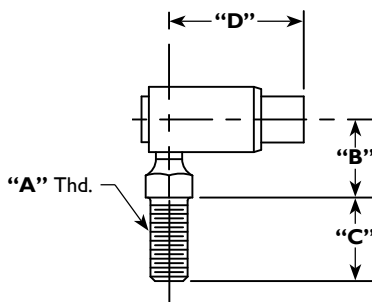

30 Series				
Part Number	"A" Thd	"B"	"C"	"D"
08-0005-01	1/4-28	.47 (11.9)	.56 (14.2)	.91 (23.1)
08-0005-02	10-32	.47 (11.9)	.44 (11.2)	.91 (23.1)
40 Series				
08-0004-01	1/4-28	.47 (11.9)	.56 (14.2)	.97 (24.6)
60 Series				
08-0021-01	5/16-24	.59 (15.0)	.69 (17.5)	1.25 (31.7)

All Dimensions are in inches (mm)

Terminal Eye

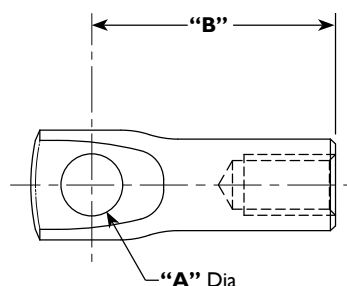

40 Series (1/4-28 Thread)		
Part Number	"A" Dia	"B"
02-1600-22	.255 (6.5)	1.00 (25.4)
02-1600-35	.193 (4.9)	1.00 (25.4)
02-1600-58	.265 (6.7)	1.50 (38.1)

All Dimensions are in inches (mm)

Shim

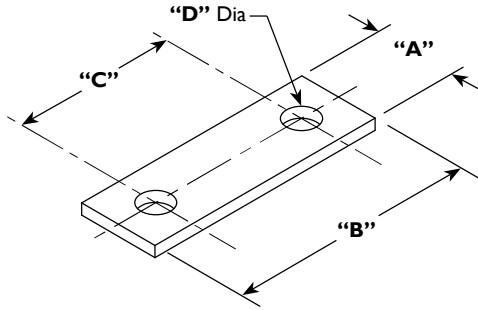

30 Series				
Part Number	"A"	"B"	"C"	"D" Dia
08-0010-01	.50 (12.7)	1.50 (38.1)	1.00 (25.4)	.203 (5.1)
40 Series				
08-0010-02	.50 (12.7)	1.50 (38.1)	1.00 (25.4)	.218 (5.5)
60 Series				
08-0010-03	.62 (15.7)	1.75 (44.4)	1.25 (31.7)	.281 (7.1)

Clamps

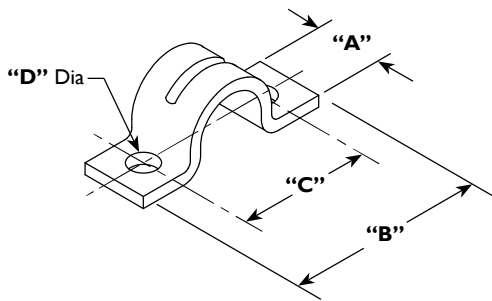

30 Series				
Part Number	"A"	"B"	"C"	"D" Dia
08-0009-01	.50 (12.7)	1.50 (38.1)	1.00 (25.4)	.203 (5.1)
40 Series				
08-0009-02	.50 (12.7)	1.50 (38.1)	1.00 (25.4)	.218 (5.5)
60 Series				
08-0009-03	.62 (15.7)	1.75 (44.4)	1.25 (31.7)	.281 (7.1)

U-Bolt Assembly

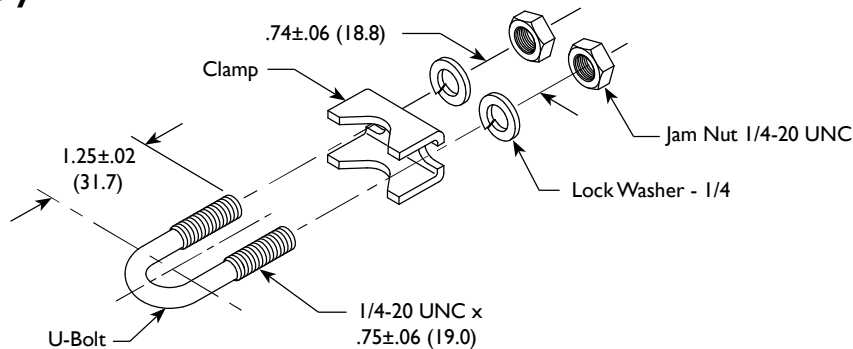

40 and 60 Series	
Part Number	
01-5000-14	

Brackets

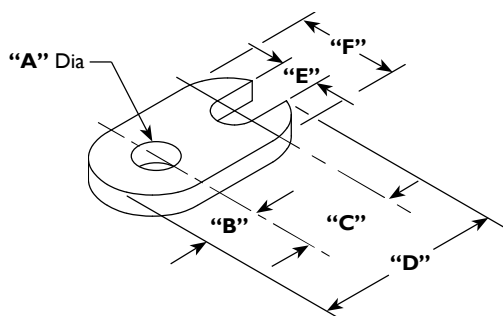

30 Series						
Part Number	"A" Dia	"B"	"C"	"D"	"E"	"F"
08-0008-01	.281 (7.1)	.38 (9.6)	.62 (15.7)	1.29 (32.8)	.272 (6.9)	.62 (15.7)

TAKE A LOOK AT OTHER WESCON PRODUCTS



Brake Cable and Lever Systems

Welded construction and zinc plating are incorporated in every Wescon brake lever for stamina and quality assurance. Optional adjustment lock-down screws and zinc plated / yellow chromate dipped cable connection hardware kits are also available.

Wescon brake cables are built with a conduit construction that allows high loads to be carried with low compressive deflection. All linings and coverings are formulated to reduce friction, abrasion, contamination and ultimately maximize efficiency.

Consult your Wescon representative for proper applications and recommendations.



Panel Control Systems

Our Power Take-off (PTO), Turn-to-Lock and Vernier control systems are all backed by a one-year replacement warranty and a wide range of options to meet your specific needs. The PTO is designed for your remote PTO shifting operations and its rugged polymer conduit cover is built to withstand harsh environments. In severe vibration applications where a reliable lock is needed, the Turn-to-Lock can be used for chokes, throttles, engine shut-offs and valves. The latest model of our Vernier control system gives you the capability of precise RPM settings with a secure construction that reduces corrosion and temperature hazards.

Contact your Wescon representative for specifications, prices and delivery dates.



Remote Valve Control Systems

Look to Wescon for your remote valve applications. Wescon's Remote Valve Control (RVC) has been engineered to place versatility in the hands of the installer. Our center or end-locking feature, thumb activated by the "Big Red Button", can help your system meet OSHA Standards. We also offer options such as bent levers to fit your mounting requirements, electric switches installed in the lever, or an adjustable friction device to "customize" your lever resistance. A wide selection of control heads, conduit, connection hardware kits, and mounting systems makes it easy to choose Wescon for your RVC application.



Light Duty Cable Control Systems

Our light duty cable control systems are engineered to help your equipment run smoother while complementing the functionality and the aesthetics of your product. Call the Wescon team to help you design controls that add to the marketability of your products.



Controls for a world in motion

WESCON CONTROLS, LLC

2533 S. West Wichita, Kansas 67217
316-942-7266 or call toll free 1-800-835-0160
Fax 316-942-5114

www.wesconcontrols.com

ISO 9001 CERTIFIED