

Electronic Twist Throttle



Engineering Specification

Document control

Document name	Electronic twist throttle specification
Document number	STC/MS/TPS01/2022/04
Date of release	27 th April 2022
Security classification	Confidential
Document owner	Suprajit Engineering Limited

Version Control

Version no	Change from the previous version	Date of Change	Author
00	New release	27 th April 2022	Deepak Yogesh

Note-

The information shared in this document is highly confidential and Belongs to **Suprajit Engineering Limited**. This information would not be disclosed or reproduced in any manner to anyone.

Table of contents

Sl No.	Contents	Page No.
01	Introduction	03
02	Technical specification sheet	03
03	Throttle packaging	04
04	Material details	05
05	Interface details	05
06	Validation requirements	07
07	Classification of functional status	08
08	Deliverable	08

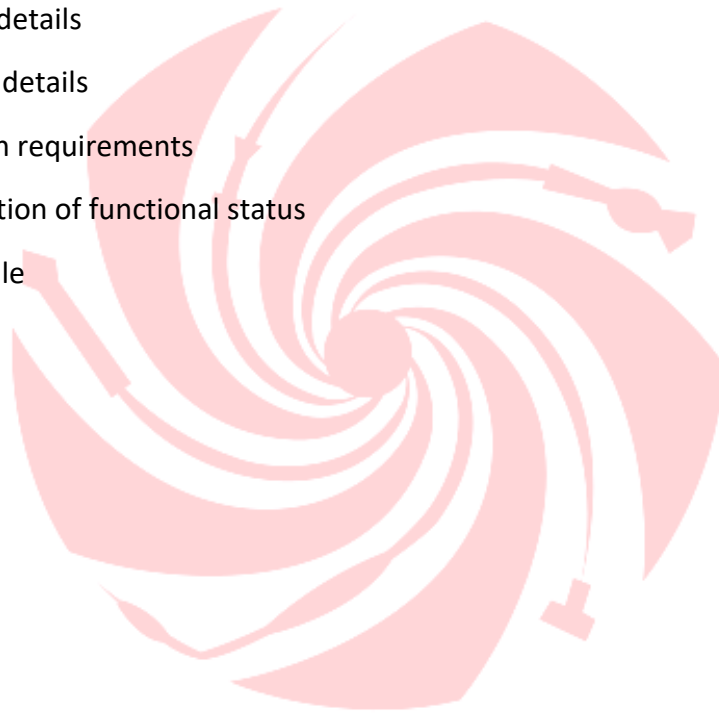

1. Introduction

The electronic twist throttle converts mechanical rotation into a precise electrical analog voltage signal which varies between 0V to 5V DC to the vehicle controller which drives the motor.

The throttle produces analog signals using a single or dual-channel hall sensor and magnet.

The total angular travel of the throttle is 65° in a clockwise direction.

2. Technical specification sheet

SL.No	Key parameters	Specification
1	Supply voltage	4.5 to 5.5V DC
2	Current consumption	<13 mA/channel or <8mA/channel
3	Channel	Single channel
4	Output voltage	0.5V to 4.5V
5	IP rating	IP67
6	Operational torque	0.3±0.1Nm
7	Operating angle	65±3° clockwise
8	Operating temperature	-20° to +80°C
9	Endurance requirement	5L cycles
10	Corrosion Resistance requirement	72 hrs against white rust 144 hrs against red rust
11	Handlebar diameter	Ø22.4mm
12	Storage temperature	-30° to +80°C
13	EMI & EMC	As per AIS 00004 Part III
14	Weight	120gm

3.Throttle packaging



Fig 1: Isometric view

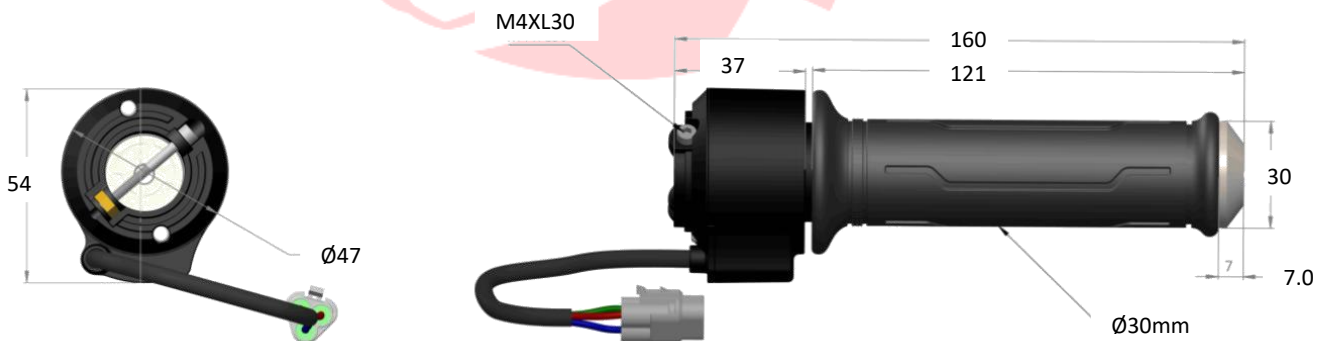
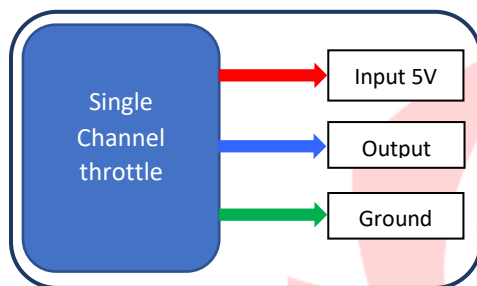

Fig 2: Packaging dimension

4. Material details

- a. Casing: ABS
- b. Hand grip: Thermoplastic elastomer
- c. Spring: Spring steel Gr III

5. Interface details



Single-channel

Coupler detail

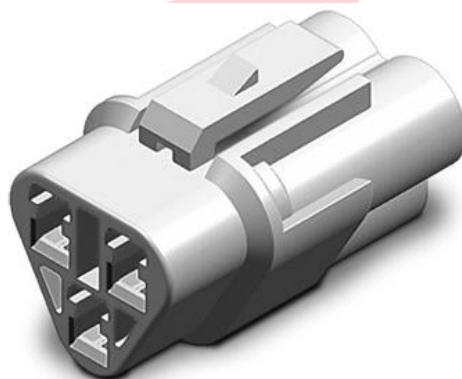

Fig 4: TTP-03 FN(WS) Coupler

6. Validation requirements

SI No	Test name	Test details	Acceptance criteria*
01	Thermal shock test IS 10250, 1982 Clause 4.5	Upper Temperature 80°C, Lower Temp 20°C, Duration/ Cycle 1 hour, No. Of Cycles: 5	DUT should meet Class A requirement
02	Vibration Test Reference Test Std. - IS 10250, 1982, Clause 4.1	Frequency 50Hz to 100Hz, Duration: 10 hours per plane acceleration 5G	DUT should meet Class A requirement. No failure, deformation cracks, or other material degradation.
03	Salt spray test	Test duration: 144 hours, against red rust Temperature: 25°C (RT)	No evidence of damage due to corrosion or electrolysis. DUT Should meet Class B
04	Dry heat test Reference Test Std. - IS 10250 1982, clause 4.2	Test duration: 16 hours, Temperature: 80°C (RT)	DUT should meet Class A requirement
05	Cold test Reference Test Std. - IS 10250 1982, Clause 4.4	Test duration: 16 hours, Temperature: -10°C (RT)	DUT should meet Class A requirement
06	Water spray test Reference Test Std. - IS 10250 1982, clause 4.13	Spray on time: 1 hour, Spray off time: 3 hours, Mounting surface sealed duration: 24 hours	DUT should meet Class A requirement
07	Dust test Reference Test Std. - IS 10250 1982, clause 4.6	Dust type: Fine powder or Portland cement, Duration: 5 hours	DUT operating torque should be same before & after test. DUT Should meet Class B
08	Short circuit protection ISO 16750 Part 2 2006 Clause 4.1	Connect input & output of DUT in sequence for duration of 60sec to max voltage and to ground	DUT should meet Class A requirement
09	Reverse polarity test	Interchange input & ground terminals and supply 5VDC for 60sec	Part should be functional after test, No electrical failure. DUT should meet Class A requirement
10	Over voltage test	Increase supply voltage to 12V and hold for 60sec	Part should be functional after test, No electrical failure. DUT should meet Class A requirement
11	Current drawn test	Measure the output current by providing 5V DC input to DUT	Output Current drawn should be less than 13.5 mA

12	Functional test	Measure Output voltage at 0° and 65° rotation	At 0° output should be 0.8±0.2 V & at 65° output voltage should be 4.5±0.2V
13	Humidity test Reference Test Std. - IS 10250 1982, clause 4.3	Humidity 95% RH, Temperature 60°C, Duration: 16 hours.	No failure, Deformation cracks, or other Material Degradation.
14	Drop and topple test Reference Test Std. - IS 10250 1982, clause 4.10	Floor concrete, No. Of drops: 6, No. Of topple 6	No failure, Deformation cracks, or other Material Degradation, DUT should be functional after the test
15	Fluid Resistance Test Reference Test Std. - IS 10250 1982, clause 4.9	Fluids: Brakes fluid, Transmission fluid, etc., Duration: 24 hours of exposure	No failure, Deformation cracks, or other Material Degradation.
16	Throttle Operation durability test	Test cycles: 0.5 million, 1 cycle = 0° to 65° and back to 0° throttle grip movement	Shall meet performance criteria throughout the test.
17	Ingress Protection test	DUT to be tested for IP67 Protection	Part should be functional after test and no water ingress allowed on electrical circuit
18	Transients on the supply ISO 7637 -2:2011	The test pulses 3a & 3B are described in ISO 7637-2:2011. Supply voltage of test must be 5V	DUT should meet Class A requirement
19	RF-Immunity to Interference using- Antennas AIS00004 Part III	Standard test condition according to ISO 11452-2 shall be applied. For RF immunity to interference against RF fields.	DUT should meet Class A requirement
20	RF-Immunity to Interference using- Bulk current injection AIS004 Part III	Standard test condition according to AIS 004 shall be applied. For RF immunity to interference against RF fields.	DUT should meet Class A requirement
21	Radiated emission	Standard test condition according to AIS 004 shall be applied.	DUT should meet Class A requirement
22	UV resistance	All plastic part to resist against UV rays for 600hr	Discoloration, chalking or silver streaks on visible areas are not allowed.

7. Classification of functional status

- Class A:** All functions of the system or component perform as designed. No visual evidence of distortion or wear. Dust may accumulate on a moist joint. No droplets form.
- Class B:** All functions of the system or component perform as designed. One or more components may go beyond specified tolerances. Components would indicate evidence of use. Parts would not typically be replaced if serviced.
- Class C:** One or more functions of a system or component do not function as designed. Components exceed design specifications. Customer would typically not be aware of the issue. System able to drive and carry torque. Parts would be replaced during service.
- Class D:** One or more functions of a system or component do not function as designed. Components exceed design specifications. Customer would be aware of the issue. Unit is functional but operation would be stopped to make repair when convenient.
- Class E:** One or more functions of a system or component do not function as designed. Components exceed design specifications. Customer would be aware of the issue. Operation would be stopped immediately to make repair. Operation suspended.

8. Deliverable

- A. Packaging 3D Model
- B. 2D Assembly drawing
- C. DVP as per mutually agreed Test Specification Document
- D. Installation & Handling Guidelines

End of Document